

1600F1

OPERATING INSTRUCTIONS

1600F1, 5 Bar Ceramic Plate Extractor

August 2015

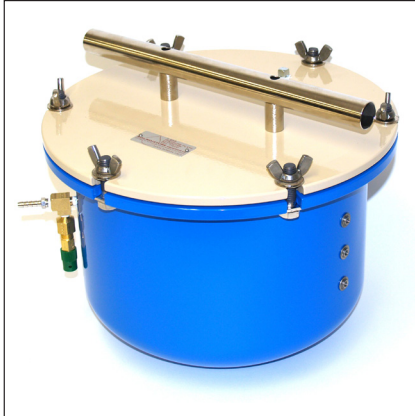

Fig. 1-1600F1 5 Bar Pressure Plate Extractor

The #1600F1, 5 Bar Ceramic Pressure Plate Extractor provides a sturdy, positive sealing pressure vessel that accepts the various Pressure Plate Cells available for work in the range of 0-5 Bars of soil suction, the primary growth range. The vessel is constructed of steel and has a working pressure of 75 PSI (5 Bars). All steel parts are plated for corrosion resistance and the inside surface of the vessel is coated with Neoprene.

PRODUCT ENHANCEMENT

Soilmoisture has improved the longevity of the interior coating, particularly under high saline or harsh conditions, with our new Water + protective coating.

The 1600F1 extractor had only a single coating of polyester. Our new 1600F1 Extractor has the Water + coating which adds two additional layers of protection. The first layer is zinc with phosphate conversion, per ASTM B633, Type 4, SC4. SC4 is for "Very Severe: Exposure to harsh conditions, or subject to frequent exposure to moisture, cleaners, and saline solutions, and damage by denting, scratching, or abrasive wear. F2/Zn 25 microns." The second layer is zinc rich powder primer; and the third layer is a polyester powder coating.

TABLE OF CONTENTS

	PAGE
Unpacking and initial assembly.....	2
Function of the ceramic pressure plate cells.....	3-4
Application of extractor and operating details.....	6
Pressure supply and control.....	6
Making a run for moisture-retention studies.....	8
Precautions.....	9
Maintenance.....	9-10

UNPACKING THE EXTRACTOR and INITIAL ASSEMBLY

The unit is shipped with the lid of the Pressure Vessel clamped in place on the tank, and all fittings are packed inside the vessel. If Pressure Plate Cells have been ordered with the unit, they may also be packed inside the vessel. (Pressure Plate Cells must be ordered separately as they are not a standard part of the unit.) Make sure to remove all packing material and tape when you remove the unit from the packing box.

Remove Lid

Loosen the eight Clamping Bolts around the edge of the unit by turning several turns. Do not remove the wing nuts from the Clamping Bolts. The Bolts have special rectangular heads that fit into a constraining groove in the bottom of the lower clamping ring. Slip the Bolts out of the slots. (When you replace the Clamping Bolts, always be sure that the heads are properly fitted into the constraining groove.)

Remove the Extractor lid by lifting it straight up. If it appears to “stick”, break the seal by forcibly lifting at one edge to break contact between the sealing “O” ring and the lid.

Handle the lid carefully so the under side of the sealing area is not scratched or damaged. Lay it down with the handle down and the “O” ring (seated in the groove in the lid) facing up. Any damage will prevent the unit from sealing properly. The “O” ring makes a pressure seal on the top of the lower clamping flange.

Next remove the contents, including all packing, from the vessel. Check to be sure all parts are there: 3 plug bolts with “O” rings; 4 outflow tubes with “O” ring and rubber tube attached; and 12 stainless steel support clips. If Ceramic Pressure Plate Cells have been ordered, they will be included. When you remove the Ceramic Pressure Plate Cells, be very careful to avoid sharp blows or rough treatment that can cause cracking or breaking.

Figure 1 on the cover page shows details of the essential operating parts. Assemble the Extractor to become familiar with the various parts and features that are involved in soil moisture extraction work.

Install the Outflow Tube and Plug Bolts

Install the Outflow Tube fittings and Plug Bolts first. (See Fig. 1) Remove the 6” length of rubber tubing from the Outflow Tube Fitting before screwing the Fitting into the outlet port in the side of the tank. A

maximum of four Outflow Tube Fittings can be screwed into the four ports. Three Plug Bolts are provided for sealing any unused ports. The pressure seals at the outlet ports are made by a Neoprene “O” ring recessed into the head of the Outflow Tube Fitting and Plug Bolt. Before initially installing the Outflow Tube Fittings or Plug Bolts, apply a small amount of Stopcock grease or Vaseline on the exposed portion of the “O” ring to lubricate it as it slides against the wall of the vessel when being screwed into place. Only a small amount of pressure is required to make the outlet port seal. A standard $\frac{1}{2}$ ” wrench or small crescent wrench can be used to tighten the fittings. Tighten the fittings only enough to bring the outer edge of the fitting in contact with the flat surface of the outlet port on the pressure vessel wall. This provides the proper compression on the “O” ring to make the seal. Further tightening will damage the fitting and shorten the life of the “O” ring seal.

Install the Pressure Plate Cells

Mount the ceramic Pressure Plate Cells in the Tank. The Extractor is designed to accept a maximum of 4 Pressure Plate Cells, one stacked above the other. First install one Stainless Steel Support Clip for the first Cell into each of the three racks provided. Face the broad, flat surface of the Clip up and place the top prong of the Clip into the second notch from the bottom of the rack. The bottom prong is then snapped into the bottom notch of the rack. Pinching the Clip with your fingers while inserting it is helpful. The vertical racks are numbered to make it easy to keep the three Clips on the same plane.

Next, attach the 6” length of Rubber Tube to the Outflow Stem of the first Pressure Plate Cell. Support the Cell by placing your fingers directly behind the Outlet Stem when you push the Rubber Tube over the Outlet Stem. Set the Cell, with the Rubber Tube attached, on the three clips with the Tube up. Push the free end of the Rubber Tube over the end of the Outflow Tube that projects into the tank.

Mount up to three more Cells the same way as the first Cell. When you mount more than one Cell, spacing is important. The notches on the racks are spaced $\frac{1}{2}$ ” apart, center to center. The Outlet Ports are spaced 1- $\frac{1}{2}$ ” apart, center to center. Therefore, the spacing from top of Clip to top of Clip should be THREE (3) NOTCHES APART.

If all four Cells are not used, the remaining Ports in the side of the tank must be plugged with the Plug Bolts provided. Then center the lid on the tank and clamp it in place with the six Clamping Bolt Assemblies. Make sure that the rectangular heads of the Bolts are properly seated in the constraining groove on the bottom side of the Lower Clamping Ring.

Function of the Ceramic Pressure Plate Cells

It is important to thoroughly understand the physical principles involved in the extraction process and how the Pressure Plate Cells function to work effectively with this type of extraction equipment. The diagram (Figure 2, page 4) shows a cross section view of a Pressure Plate Cell mounted in a pressure vessel with the Outflow Tube running through the vessel wall to the atmosphere. A soil sample is held in place on the porous ceramic surface of the Cell.

Each Pressure Plate Cell consists of a porous ceramic plate covered on one side by a thin Neoprene diaphragm sealed to the edges of the Plate. An internal screen between the plate and diaphragm provides a passage for the flow of water. An Outlet Stem running through the plate connects this passage to an Outflow Tube Fitting, which connects to the atmosphere outside the Extractor.

To use the Pressure Plate Cell, place the soil samples on the porous ceramic surface and hold them in place with Retaining Rings of appropriate heights. Then saturate the soil samples together with the porous

ceramic Plate. This is usually done by allowing an excess of water to stand on the surface of the Cell for several hours. After the porous ceramic plate in the Pressure Plate Cell and the soil sample are completely saturated with water, the Cell can be mounted in the Pressure Vessel. Then use air pressure to extract moisture from the soil sample(s) under controlled conditions.

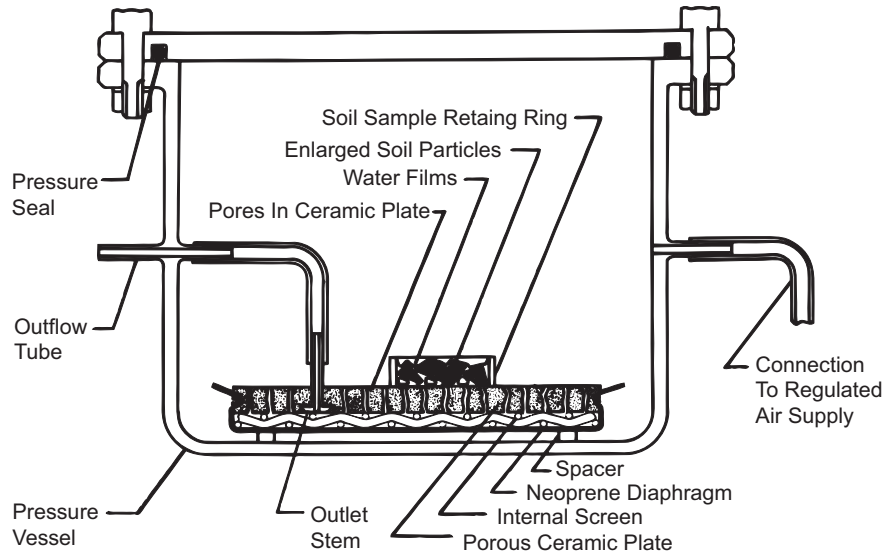

(Fig.02) Cross Section View of Ceramic Pressure Plate Cell and Soil Sample, in Extractor

As soon as air pressure inside the chamber is raised above atmospheric pressure, the higher pressure inside the chamber forces excess water through the microscopic pores in the ceramic plate and out through the Outlet Stem via the passage afforded by the screen. However, the high pressure air will not flow through the pores in the ceramic plate since the pores are filled with water and the surface tension of the water, at the gas-liquid interface at each of the pores, supports the pressure much the same as a flexible rubber diaphragm. To understand this action more thoroughly, refer to Fig. 3 below.

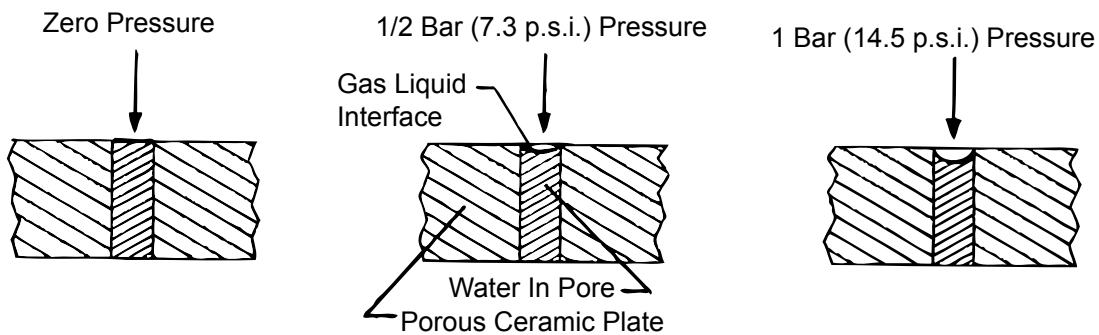

(Fig.03)

Changes in Radius of Curvature of Gas-Liquid Interface With Pressure

ZERO PRESSURE ½ BAR (7.25 P.S.I.) PRESSURE 1 BAR (14.5 P.S.I.) PRESSURE

The maximum air pressure that any given wetted porous ceramic plate can stand before letting air pass through the pores is determined by the diameter of the pore. The smaller the pore size, the higher the air pressure will have to be to pass through. The pressure value that finally breaks down these water meniscuses is called the “Bubbling Pressure” or the “Air Entry Value” for the porous plate. Pressure Plate

Cells must always be used at air pressure extraction values below the “Bubbling Pressure” or “Air Entry Value” for the Cell.

During a run at any set air pressure in the Extractor, soil moisture will flow from around each of the soil particles and out through the ceramic plate until the effective curvature of the water films throughout the soil are the same as at the pores in the plate. When this occurs, an equilibrium is reached and the flow of moisture ceases. When the air pressure in the Extractor is increased, flow of soil moisture from the sample(s) starts again and continues until a new equilibrium is reached. At equilibrium, there is an exact relationship between the air pressure in the Extractor and the soil suction (moisture content) in the sample(s).

For example, if the air pressure in the Extractor is maintained at 1/3 Bar (4.8 PSI), the soil suction in the sample(s) at equilibrium will be 1/3 Bar. * If the air pressure is maintained at 1 Bar (14.5 PSI), the soil suction at equilibrium will be 1 Bar. Fig. 4 below shows the moisture retention curves for three different soil types that can be developed with this type of equipment. These “moisture characteristic” curves for each soil are extremely important in soils research and in the development of practical, effective irrigation practices.

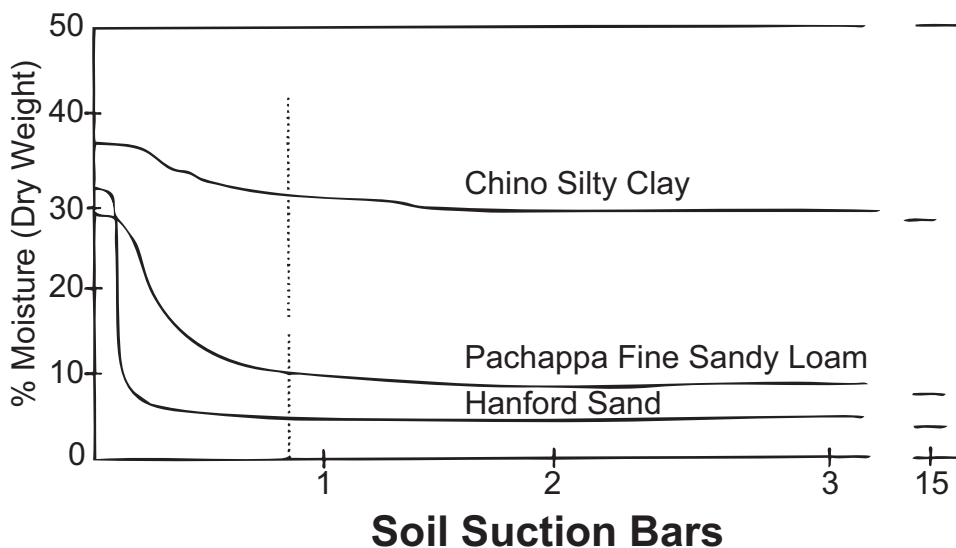

(Fig.04) Moisture Retention Curves

Moisture Retention Curves are shown for three types of soils. The dotted line at .85 bars of soil suction represent the limit of tensiometer readings.

Application of Extractor and Operating Details

The #1600F1, 5 Bar Pressure Plate Extractor provides a sturdy, positive sealing pressure vessel that accepts the various Pressure Plate Cells available for work in the range of 0-5 Bars of soil suction, the primary growth range. The vessel is constructed of steel and has a working pressure of 75 PSI (5 Bars). All steel parts are plated for corrosion resistance and the inside surface of the vessel is coated with Neoprene. The Extractor will accept the #0675B1M3, 1 Bar Pressure Plate Cell; the #0675B03M1, 3 Bar Ceramic Plate Cell; and the #0675B05M1, 5 Bar Ceramic Plate Cell.

The 1 Bar Pressure Plate Cells are ideal for the routine determination of the 1/10 Bar and 1/3 Bar

percentage in the cataloging of soils as well as all other soil moisture equilibrium studies in the 0-1 Bar range of soil suction. The bubbling pressure of these cells is in excess of 1 Bar (14.5 PSI) and is usually between 18 and 25 PSI. These Cells also have the highest permeability of any of the Pressure Plate Cells, and therefore, provide the shortest possible time to reach equilibrium

The, #0675B03M1, 3 Bar Pressure Plate Cells can be used for determination of the 1/10 Bar and 1/3 Bar percentages as well as soil moisture equilibrium studies in the extended range of 0-3 Bars of soil suction. Bubbling pressure of these Cells is in excess of 3 bars (43.5 PSI) and is usually between 55 and 65 PSI.

The #0675B15M1, 15 Bar Pressure Plate Cells are not suitable for work in the 0-1 Bar range of soil suction due to their small pore size and relatively high permeability. However, they can be used effectively in this Extractor for soil moisture equilibrium studies in the 1-5 Bar range of soil suction. Bubbling pressure of these Cells is in excess of 15 Bars (220 PSI). For full range use, these Cells must be used in the #0675B15M1 15 Bar Pressure Plate Extractor.

The Various Pressure Plate Cells are not suitable for extracting solution from soils for chemical analysis. The immense surface area within the porous ceramic plate can cause disturbance and contamination of the soil solution. For extraction of the soil solution for chemical analysis, the #1000 Pressure Membrane Extractor must be used.

*Note; The "Bar" has become a standard unit for the expression of soil suction. By definition, a Bar is a unit of pressure equal to 106 dyne/cm². This is equivalent to .987 atmospheres or 14.5 PSI.

Pressure Supply and Control

A source of regulated gas pressure is required for all extraction work. Compressed air from a compressor or compressed air or Nitrogen in high-pressure tanks can be used. If the Extractor is to be used extensively, compressed air from a compressor is the most satisfactory source of supply. Our #0505 Laboratory Compressor is ideally suited for use with this Extractor and all of our Extractors. It is available in a variety of voltages and cycles to meet any application.

Regulation of the air supply determines the accuracy of the equilibrium values. For work in the low soil suction range and, particularly for determination of the 1/10 Bar and 1/3 Bar percentages, it is essential to have excellent pressure regulation. We recommend our #0700G3F1 Manifold that makes use of a low-pressure regulator in series with a "Nullmatic" type regulator that provides double regulated pressure to within 1/100 PSI throughout the range from 0-100 PSI. Our #0776L60Connecting Hose is used to connect the Extractor to the Manifold.

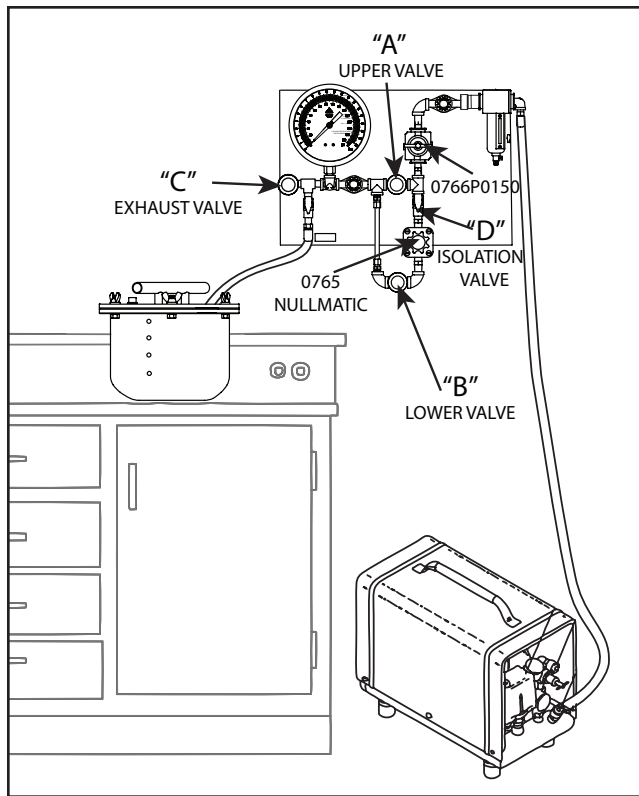

(Fig.05) Lab03V1 Compressed Air as a Pressure Source

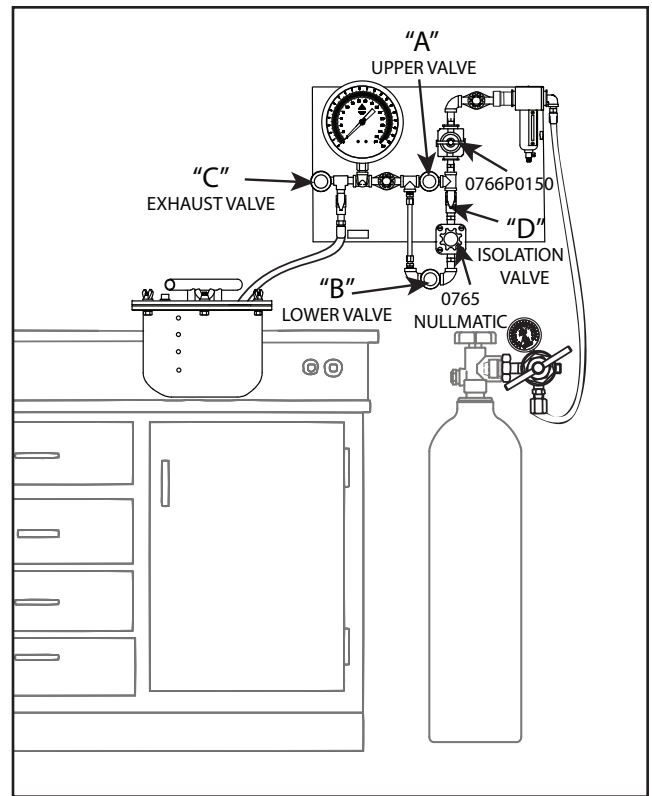

(Fig.06) Lab053 - Nitrogen as a Pressure Source

Fig. 5 shows a diagram of the Laboratory Setup for the #1600F1 Extractor using regulated air pressure from the LAB03V1 Manifold and the #0505V Laboratory Compressor as a pressure source. The LAB03V1 Manifold is frequently incorporated in combination manifolds such as the LAB023V, LAB033V, or LAB123V, where several different types of Extractors are being run independently from the same pressure source.

If a laboratory compressed air supply line is available; the LAB003V Manifold can be conveniently attached to the laboratory wall adjacent to the Extractor and connected directly to the supply line. Maximum input pressure to this Manifold is 300 PSI.

The Catalog No. 1600F1 Extractor can also be operated from compressed air or Nitrogen in tanks. Our LAB053 Manifold is designed for use with water pumped Nitrogen in tanks (approx. 2000 PSI) and is applicable where the Extractor is used on a limited basis and in remote locations. This manifold has a pressure range from 0-100 PSI with an accuracy of regulation of approximately .2 PSI. Fig. 6 shows this Laboratory Setup.

The LAB053 Manifold may also be incorporated in combination manifolds such as LAB013, LAB0513, or LAB0523, where several different types of Extractors are being run independently from the same pressure source. The 750 series Manifolds incorporate a # 0767P0300G1 Regulator, which is designed to mount directly on tanks of water pumped Nitrogen with a tank fitting designated as CGA #580 that is standard.

Be careful in the selection of proper components if a pressure control setup is to be built up by laboratory technicians. Proper pressure regulators, test gauges, valves and miscellaneous adapters are available at Soilmoisture Equipment Corp. Please refer to our current price list. In general, the type of pressure regulator required will depend on the type of pressure source and on the accuracy required for the studies

being conducted. Accuracy of regulation is dependent upon the construction of the regulator and on variations in the pressure from the source of supply.

When using regulators suitable for use with this Extractor, variation in the source pressure will be reflected in the regulated pressure in the ratio of about 1/12 to 1/25. In other words, a change in the pressure from the compressed air source of 25 PSI will change the regulated pressure by 1 to 2 PSI depending on the make of regulator. If you need greater accuracy, using "Double regulation" can eliminate this variation. Double Regulation is putting two regulators in series. The first regulator is set at a somewhat higher pressure than the second in order to supply reasonably constant pressure to the second regulator. Pressure from the second regulator in turn will be very constant with source pressure variations reduced in the ratio of 1/100.

Where extreme accuracy of regulation is required, nullmatic regulators, which bleed a small amount of air continuously, are necessary. Because of this feature, they are not suitable for use with tank gas and must be used where a compressor is the source pressure.

Making a Run For Moisture-Retention Studies

If you are running moisture equilibrium studies, keep sample heights small so the time to reach equilibrium is reasonable. The time required to reach equilibrium varies according to the square of the sample height. For example, a soil sample 2-cm high will require four times as long to reach equilibrium as a 1-cm high sample. Soil sample heights should be limited to 1-cm when possible. Our #1093 Soil Sample Retaining Rings, which will hold a 25-gram sample and are 1-cm high by 5-1/2 cm in diameter, are ideal for retaining prepared samples.

Moisture retention studies can be made with prepared soil samples or with undisturbed soil cores. Frequently, soil structure is quite an important determining factor in the value of the 1/10 Bar and the 1/3 bar percentages. This should be considered before electing which kind of sample to use.

For work with undisturbed soil cores, our #200 Soil Core Sampler is a simple, effective sampler. The soil cores are retained in 2-1/4" OD brass cylinders of several possible lengths. The cores obtained can also be used directly in the #0676 Soil Retainer Assembly for development of moisture retention curves. The #0676 soil Retainer Assembly consists of a 1/4" thick, 1 Bar porous ceramic plate, a 2-1/4" OD by 3-cm long brass cylinder and a plastic cover plate, all held together with a rubber band. The Assembly will accept either undisturbed soil cores or prepared samples. A slurry of fine sandy loam can be used to establish good hydraulic conductivity between the ceramic plate of the retainer and the Cell surface when mounted for a run. The Assembly can be removed from the Extractor periodically at various equilibrium values for weighing, without disturbance to the soil sample. Agriculture handbook No. 60 should be consulted for further information on this method.

Where prepared soil samples are to be used, the procedure for determining the 1/3 Bar percentage is as follows:

Prepare duplicate 25-gm. samples that have been passed through a 2-mm round hole sieve for each soil type to be run. Place #1093 Soil Sample Retaining Rings on the ceramic plate to receive the group of samples. Each Pressure Plate Cell will accommodate 12 samples when they are retained in these rings. In order to avoid particle-size segregation, dump the entire soil sample from each container into one ring. Pouring out part of the sample and leaving part in the container will give a non-representative sample. Level the samples in the ring, cover them with squares of waxed paper, and allow them to stand at least 16 hours with an excess of water on the plate. When the samples are ready for the Extractor, remove the

excess water from the Cells with a pipette or syringe. Mount the Cells in the Extractor, connect the Outflow Tubes and close the lid of the Extractor.

To determine when equilibrium has been reached, connect each outflow tube to the tip of a burette with a piece of small diameter tubing. Gas diffusing through the ceramic plate passes continuously in small bubbles through this small outflow tube and transports the extracted liquid to the burette. Read the burette periodically to follow the equilibrium. Once equilibrium is attained, the burette reading will not measurably change for many hours or days if the pressure in the Extractor is kept constant. The pressure in the Extractor is now built up to 1/3 Bar, which is 4.83 PSI.

The 0700G3F1 station consists of a 5 to 150 psi Pressure Regulator (Model 0766P0150); a 1 to 60 psi Nullmatic Regulator (0765); a 0 to 100 psi Test Gauge (Model 0780P0100); and all the necessary valves and fittings. In making pressure settings at this station, it is important to carefully adjust both of the pressure regulators. The Nullmatic Regulator continuously exhausts a certain amount of air when it is used on "dead-end service" such as is the case with our Extractors. The amount of air exhausted is proportional to the pressure differential between the supply air and the pressure setting of the delivered air. For normal use and for maximum conservation of compressed air from the tank, the Regulator (Model 0766P0150) should be set at a pressure two to three psi higher than the equilibrium pressure you wish delivered from the Nullmatic Regulator. When this procedure is followed, the amount of air that escapes from the Nullmatic Regulator is in the order of 2/100 cu.ft. of air per minute. Keep in mind that the nullmatic is accurate in the range of 1-60 psi and the 150psi regulator is accurate in the range of 5-150 psi. If the bleeding of the nullmatic is problematic in your application (such as a limited nitrogen source), then just leave it on in the 1-5 psi range, after which valve B can be closed and the isolation valve D also closed to effectively remove the nullmatic from the system. Also note that in the range of 60-75 psi, the nullmatic must be isolated because the pressure is beyond the rated use of the unit. If you can use the nullmatic, it will provide you a little higher accuracy in stability than the 150 regulator but the tradeoff being higher air loss rate. This amount of air is very easily built up by the compressor pump in the course of its pumping cycle.

When setting the pressure for a run, the procedure is as follows (please reference (*Fig.01*)).

The valve at the end of the Connecting Hose is first closed. The Nullmatic Regulator is then opened a number of turns so that you are sure it is set at a pressure considerably above that which you plan to use. Then the Regulator (Model 0766P0150) is opened so that the pressure can flow through the Nullmatic Regulator and register on the Test Gauge. The Regulator (Model 0766P0150) is adjusted so that Pressure Gauge reads, say, three psi higher than the equilibrium pressure you plan to use in the Extractor. The Nullmatic Regulator is now closed until the excess air is exhausted up to the pressure value you desire in the Extractor and which will now be registered on the Test Gauge. The valve to the Pressure Extractor can now be opened and the regulators will maintain the pressure in the Extractor at the value set. A minor adjustment is needed at the end due to the added friction of additional path for the air to flow.

PROPER SETTING FOR USING OR EXCLUDING THE NULLMATIC REGULATOR:

If the nullmatic regulator is to be used, the upper valve A must be closed (turned clockwise to stop), the lower valve B must be open (turn counter-clockwise to stop) and the isolation valve D must be open (valve handle perpendicular to pipe).

If the nullmatic regulator is not to be used or using the 150 regulator exclusively, then the upper valve A must be open (turn counter-clockwise to stop), the lower valve must be closed (turn clockwise to stop) and the isolation valve must be closed (valve handle perpendicular to pipe).

This system for low pressure regulation is known as "double regulation" and is frequently used to provide very accurate control of pressure. All regulators reflect, in their output pressure, variations present in the pressure from the sources of supply. By placing two regulators in series, such as mentioned above, variations in the output pressure from the first regulator are considerably reduced by the second regulator so

that the output pressure from the second regulator is very constant with source pressure variations reduced in the ratio of 1:100 or more.

At the end of a run when you want to exhaust the air from the extractor, simply close valves A and B, then open up the exhaust valve C until the extractor is emptied of air. The extractor is now safe to open.

The same procedure is used to determine the 1/10 Bar percentage, except that the pressure applied is 1/10 Bar or 1.45 PSI.

Precautions

Soil particles must be kept away from the Pressure Seals and sealing areas on the Extractor. Also, do not scrape or bang the metal surfaces on the Pressure Seals. Damage to these sealing surfaces can result in leakage of air from the Extractor. This leakage is called "ventilation" and can result in erroneous equilibrium values. Any flow of air will also carry off soil moisture and reduce the equilibrium moisture content value to below actual values.

NEVER attempt to remove the lid of the Extractor until all pressure is released. Also, the lid MUST be securely fastened in place before air pressure is applied to the Extractor.

Maintenance

Evaporation Deposits on the Surface of the Ceramic Plate

After a run, cover the surface of the Ceramic Plate with a thin layer of fine dry soil and allow it to set for several days until dry. Then remove the soil and store the cell. This procedure allows the evaporation deposits to form on the soil particles instead of the surface of the ceramic plate, which should be kept as clean as possible.

Removal of Evaporation Deposits from Pressure Plate Cells

After a period of time, if the flow rate of a Cell drops due to deposits, they should be removed.

Calcium Carbonate Deposits on the Ceramic Surface

Remove Calcium Carbonate deposits on the surface of the ceramic by carefully sanding the surface with a fine or medium grade Garnet or sandpaper.

Deposits in the Pores of the Ceramic

Remove deposits in the pores of the ceramic by flushing a 10% solution of Hydrochloric or Acetic acid through the Pressure Plate Cell under pressure in the Extractor. Follow this with a similar flush of clear water.

Bacterial Action in the Pressure Plate Cell

The internal screen is made of Polypropylene to minimize this condition. If there is a problem with bacterial action, the Cell can be flushed under pressure periodically with a solution of Copper Sulfate or Mercuric Chloride using the same procedure as above.

Care of the Extractor Vessel

The Extractor lid and tank require little maintenance. They are ruggedly constructed, carefully plated and coated for maximum corrosion resistance. However, you must remove excess moisture and soil particles from the interior surfaces after a run.

Replacement pressure Sealing Rings are available for immediate shipment from stock. Catalog #M802X453PKG02 is the replacement "O" Ring Lid Seal. Catalog #M802X010PKG05 is the replacement "O" Ring Port Seal.

Replacement Parts List

ITEM PART #	DESCRIPTION
0763G5	Safety Relief Valve for Model 1600F1
0770G8	1/4" Galvanized Pipe Plug
0772G47	1/8" NPT Female Adaptor
1000-103CR	Extractor Handle Kit
1055K1	Right Angle Outflow Adapter (set of 4)
1057K1	Plug Bolt with Seal (set of 4)
1060G2	Outflow Tube Assy. 6" rubber hose, w/seal
1500-006	15-Bar Extractor-outlet insert boss
1600-001	Extractor Cover
1600-003CR	Shelf bracket
1600-006	Neoprene Pad
1600-007CR	Support Clip (set of 12)
1600-100	Tank Assembly
M802X453PKG02	O-ring Lid seal for 1500 and 1600 Extractors
MBL001-009	1/8" NPT Street "T" brass
Z1600-004	Inlet fitting, for 1600F1 extractor
Z1696K1	Clamping Bolt Kit, set of 6, for 1600F1 Extractor